

**All TUFLOC models use identical mounting specifications.**

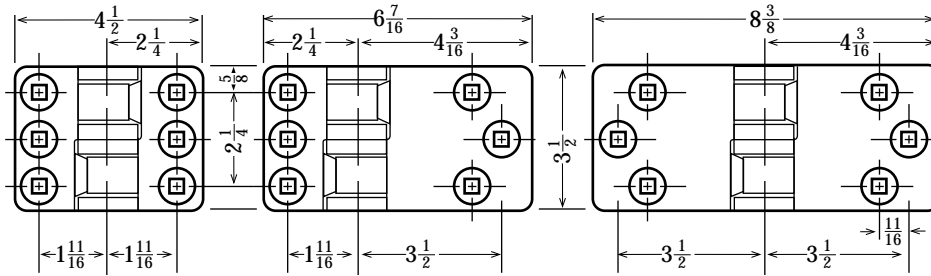

**50-1 OR 60-1**

**50-2 OR 60-2**

**50-3 OR 60-3**

Note: All right hand illustrated.

**TO ASSURE BEST RESULTS,  
ALWAYS MOUNT TUFLOC WITH KEY IN THE DOWN POSITION.**

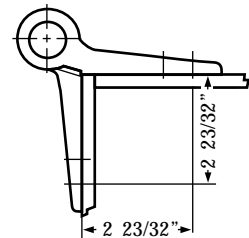
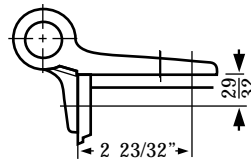
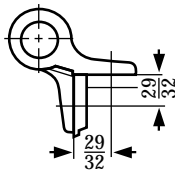
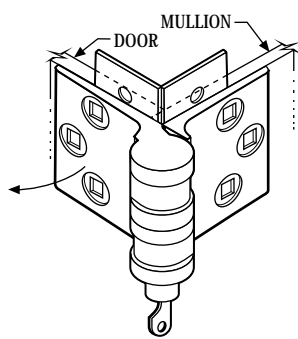

**CORNER 90° MOUNT**

With door closed, place TUFLOC into desired position. Mark location of (6) mounting holes. Remove TUFLOC and drill mounting holes using "X" (.3970) drill bit. Mount TUFLOC with 3/8" carriage bolts provided.

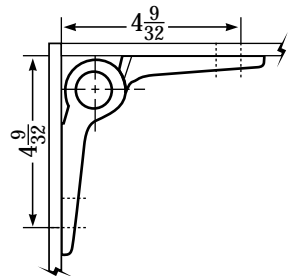
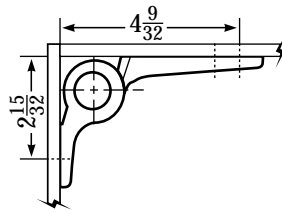
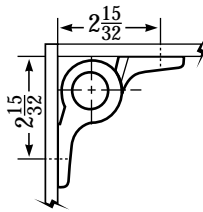
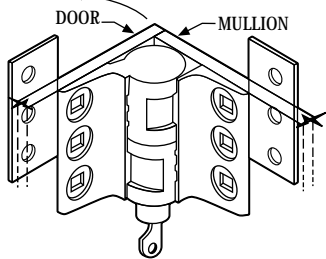

**CORNER INVERSE 90° MOUNT**

With door closed, place TUFLOC into desired position. Mark location of (6) mounting holes. Remove TUFLOC and drill mounting holes using "X" (.3970) drill bit. Mount TUFLOC with 3/8" carriage bolts provided.

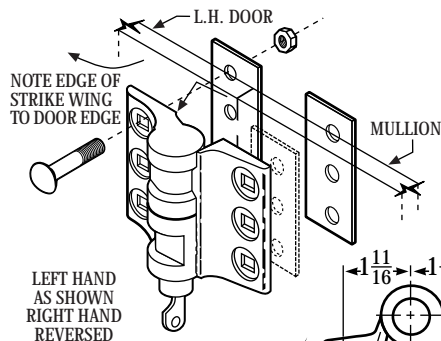

**FLUSH MOUNT**

Align edge of lock to edge of door as shown. Locate (3) holes on door and drill through using "X" (.3970) drill bit. Mount lock to door. (Note: Key down.) With door closed, locate (3) holes in mullion. Drill through and mount other wing.

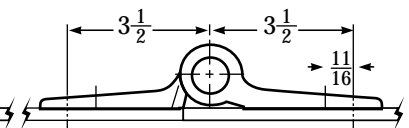
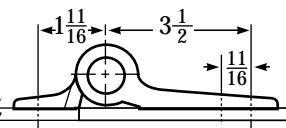
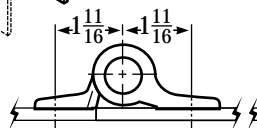

# INSTRUCTIONS

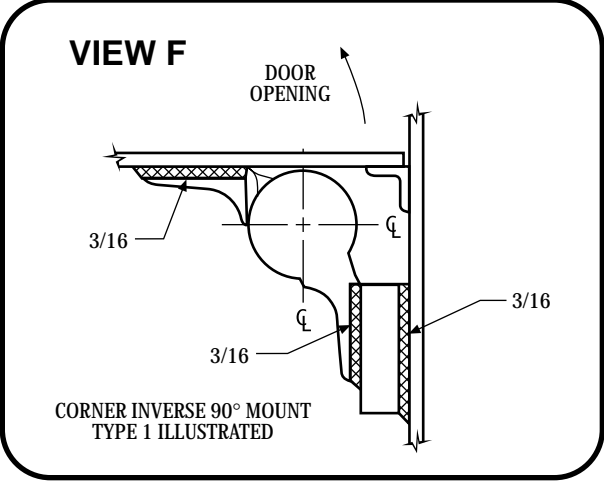
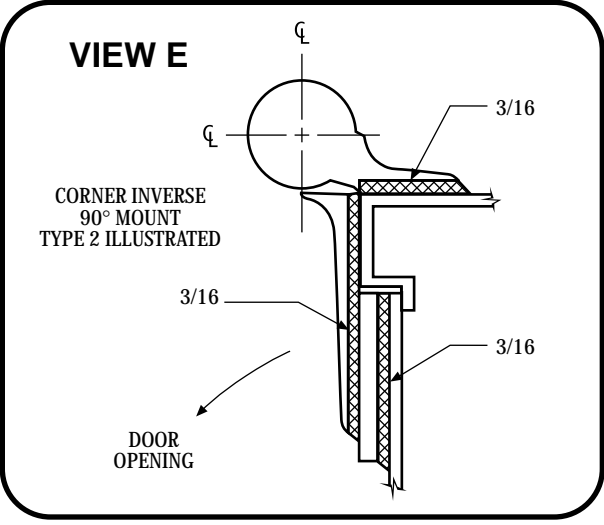
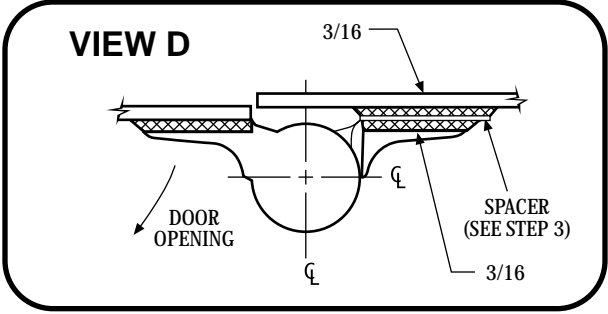
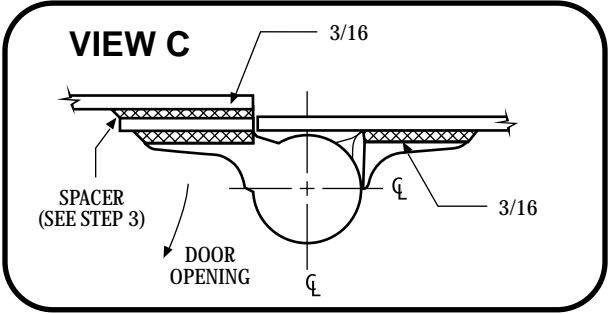
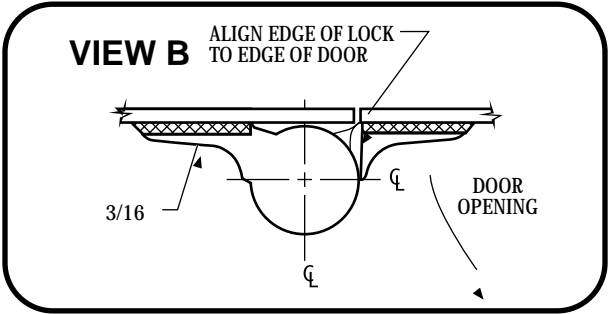
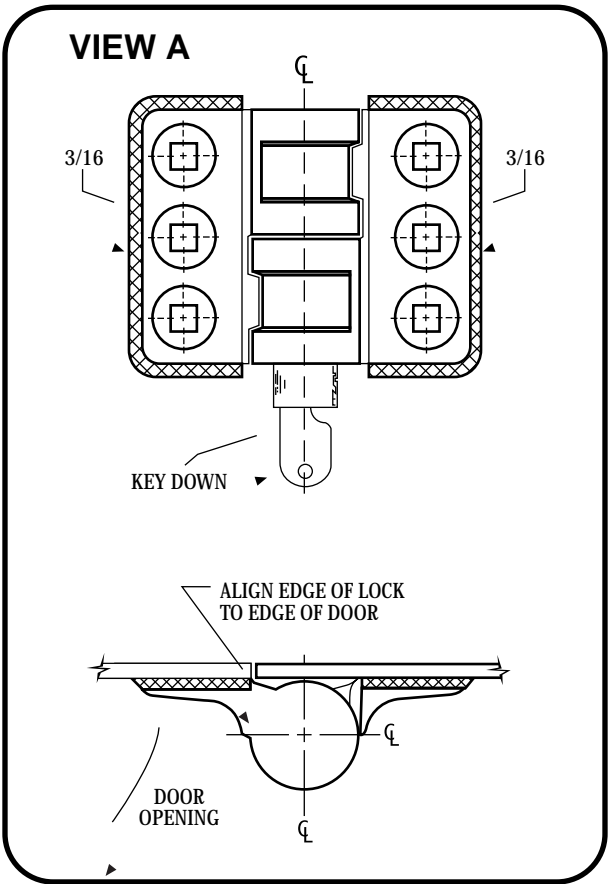

- Step 1. With door closed, place TUFLOC into desired position with edge of TUFLOC flush to edge of door. (See Views A and B)
- Step 2. While holding lock in above position, operate Central Bolt. (If Bolt moves freely, omit Step 3 and proceed to Step 4)
- Step 3. In the event the Central Bolt does not move freely and binds, Spacers will be needed. (See Views C and D) Spacers must be made of steel and must be of necessary thickness to align with both Wings of the TUFLOC, allowing free movement of the Central Bolt. Weld Spacer in place. (See note)
- Step 4. Weld TUFLOC in place using No. 310 AC-DC reverse polarity rod (conforms to Naval Ship Engineering Center Spec. MIL-E-22200/2, latest revision, Type 310-16) at 110 AMPS, standard size 1/8 diameter X 14 inches long, continuous 3/16 fillet.
- NOTE: The purpose of maintaining the Central Bolt freedom within the Lock Wings is to centrally locate the center line axis of the Lock already supplied with tolerance to maintain the Central Bolt freedom without unnecessary bind due to improper welding or spacing beyond the limits of the established tolerance within the Lock.